

***ALTEC TTP 245 Series/343 Series***

**THERMAL TRANSFER / DIRECT THERMAL  
BAR CODE PRINTER**

**USER'S  
MANUAL**

# Contents

<b>COPYRIGHT DECLARATION .....</b>	<b>1</b>
<b>COMPLIANCES.....</b>	<b>1</b>
<b>1. Introduction.....</b>	<b>1</b>
<b>2. Getting Started .....</b>	<b>1</b>
<b>2.1 Unpacking and Inspection.....</b>	<b>1</b>
<b>2.2 Equipment Checklist.....</b>	<b>1</b>
<b>2.3 Printer Parts.....</b>	<b>3</b>
<b>3. Setup.....</b>	<b>4</b>
<b>3.1 Setting Up the Printer .....</b>	<b>4</b>
<b>3.2 Loading the Ribbon.....</b>	<b>4</b>
<b>3.3 Loading Label Stock .....</b>	<b>6</b>
<b>3.4 External Label Roll Mount Installation (Option) .....</b>	<b>8</b>
<b>3.5 Peel-off Module Installation (Option).....</b>	<b>10</b>
<b>3.5.1 Loading the Paper in Peel-off Mode.....</b>	<b>13</b>
<b>3.6 Cutter Module Installation (Option) .....</b>	<b>15</b>
<b>3.6.1 Loading Label in Cutter Mode .....</b>	<b>17</b>
<b>3.7 Instructions to Top Cover Operation.....</b>	<b>18</b>
<b>3.8 Diagnostic Tool .....</b>	<b>21</b>
<b>3.8.1 Start the Diagnostic Tool.....</b>	<b>21</b>
<b>3.8.2 Printer Function (Calibrate sensor, Ethernet setup, RTC             setup.....) .....</b>	<b>22</b>
<b>3.9 Install Memory Card .....</b>	<b>23</b>
<b>4. Power on Utilities.....</b>	<b>25</b>
<b>4.1 Ribbon and Gap/Black Mark Sensor Calibration .....</b>	<b>25</b>
<b>4.2 Gap/Black Mark Calibration, Self-test and Dump Mode.....</b>	<b>26</b>
<b>4.3 Printer Initialization .....</b>	<b>29</b>
<b>4.4 Set Black Mark Sensor as Media Sensor and Calibrate the         Black Mark Sensor .....</b>	<b>30</b>
<b>4.5 Set Gap Sensor as Media Sensor and Calibrate the Gap Sensor         30</b>	<b>30</b>
<b>4.6 Skip AUTO.BAS.....</b>	<b>30</b>
<b>5. Maintenance .....</b>	<b>32</b>
<b>5.1 Cleaning .....</b>	<b>32</b>
<b>6. Troubleshooting.....</b>	<b>34</b>
<b>6.1 LED Status .....</b>	<b>34</b>
<b>6.2 Print Quality.....</b>	<b>35</b>

<b>7. LED and Button Operation.....</b>	<b>37</b>
<b>7.1 LED.....</b>	<b>37</b>
<b>7.2 Button Operation.....</b>	<b>37</b>
<b>Revise History.....</b>	<b>40</b>

# Copyright Declaration

Information in this subject to change without notice and does not represent a commitment on the part of TSC Auto ID Technology Co., Ltd.. No part of this manual may be reproduced or transmitted in any form by any means, for any purpose other than the purchaser's personal use, without the expressed written permission of TSC Auto ID Technology Co., Ltd..

## Compliances

CE Class B:

EN55022: 1998+A1: 2000+A2: 2003

EN55024: 1998+A1: 2001+A2: 2003 IEC 61000-4 Series

EN61000-3-2: 2006 & EN61000-3-3: 1995+A1: 2001

FCC Part 15, Class B

UL, CUL

C-Tick:

CFR 47, Part 15/CISPR 22 3<sup>rd</sup> Edition: 1997, Class B

ANSI C63.4: 2003

Canadian ICES-003

TÜV-GS: EN60950: 2000

## Wichtige Sicherheits-Hinweise

1. Bitte lesen Sie Diese Hinweis sorgfältig durch
2. Heben Sie diese Anleitung für den späteren Gebrauch auf.
3. Vor jedem Reinigen ist das Gerät vom Stromnetz zu trennen.  
Verwenden Sie Keine Flüssig-oder Aerosolreiniger. Am besten eignet sich ein angefeuchtetes Tuch zur Reinigung.
4. Die Netzanschlußsteckdose soll nahe dem Gerät angebracht und leicht zugänglich sein.
5. Das Gerät ist vor Feuchtigkeit zu schützen.
6. Bei der Aufstellung des Gerätes ist auf sicheren Stand zu achten. Ein Kippen oder Fallen könnte Beschädigungen hervorrufen.
7. Beachten Sie beim Anschluß an das stromnetz die Anschlußwerte.
8. Dieses das Gerät kann bis zu einer Außentemperatur von maximal 40°C betrieben werden.

# 1. Introduction

Thank you for purchasing the ALTEC TTP-245 series/343 series Thermal Transfer and Direct Thermal Bar Code Printers. Although the printer takes only a small amount of space, it delivers reliable, superior performance.

This printer provides both thermal transfer and direct thermal printing at user selectable speed of: 2.0, 3.0, 4.0 or 5.0 ips, for TTP-245 series; 2.0 or 3.0 ips for TTP-343 series. It accepts roll feed, die-cut, and fan-fold labels for both thermal transfer and direct thermal printing. All common bar codes formats are available. Fonts and bar codes can be printed in 4 directions, 8 different alphanumeric bitmap fonts and a build-in true type font capability. You will enjoy high throughput for printing labels with this printer.

## 2. Getting Started

### 2.1 Unpacking and Inspection

This printer has been specially packaged to withstand damage during shipping. Please carefully inspect the packaging and printer upon receiving the bar code printer. Please retain the packaging materials in case you need to reship the printer.

### 2.2 Equipment Checklist

- Printer
- BarTender UltraLite CD disk
- Quick start guide
- USB port cable
- External universal switching power supply
- Power Cord
- Label Spindle, fixing tab x2, 1.5" core adapter x2
- Ribbon spindle x2
- Ribbon rewind spindle paper core

If any parts are missing, please contact the Customer Service Department of your purchased reseller or distributor.

### **Dealer option**

- Peel off module assembly.
- Guillotine cutter

#### **Full cut:**

Paper thickness: 0.06~ 0.19mm, 500,000 cuts

#### **Partial cut:**

Paper thickness: 0.06~0.12mm, 500,000 cuts

Paper thickness: 0.19mm 200,000 cuts

- Main board integrated with internal Ethernet
- Internal Ethernet print server module

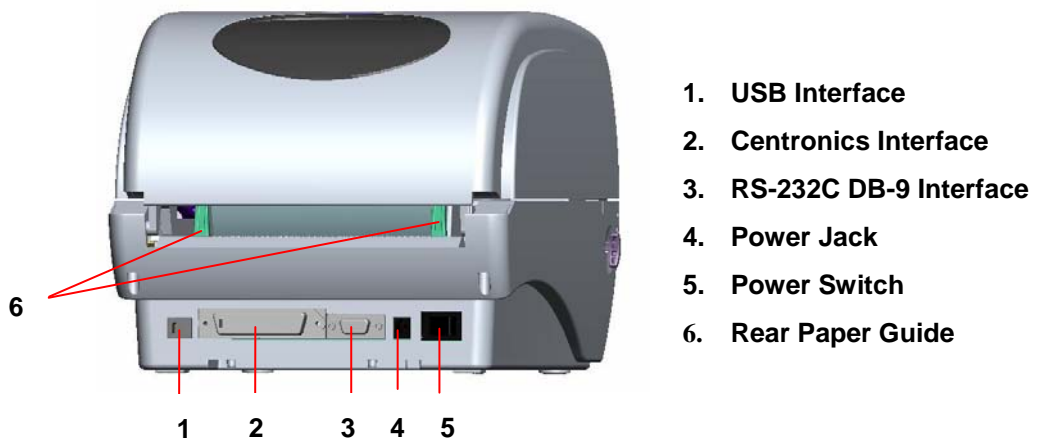
### **User option**

- KP-200
- KU-007 plus
- External Ethernet print server
- External wireless (802.11b/g) print server
- External roll mount, media OD. 214 mm (8.4") with 3" core label spindle
- Contact CCD contact scanner
- Long range linear image bar code scanner

## 2.3 Printer Parts



**Fig. 1 Top front view**



**Fig. 2 Rear view**

## 3. Setup

### 3.1 Setting Up the Printer

1. Place the printer on a flat, secure surface.
2. Make sure the power switch is off.
3. Connect the printer to the computer with the Centronics or USB cable.
4. Plug the power cord into the power supply connector at the rear of the printer, and then plug the power cord into a properly grounded receptacle.

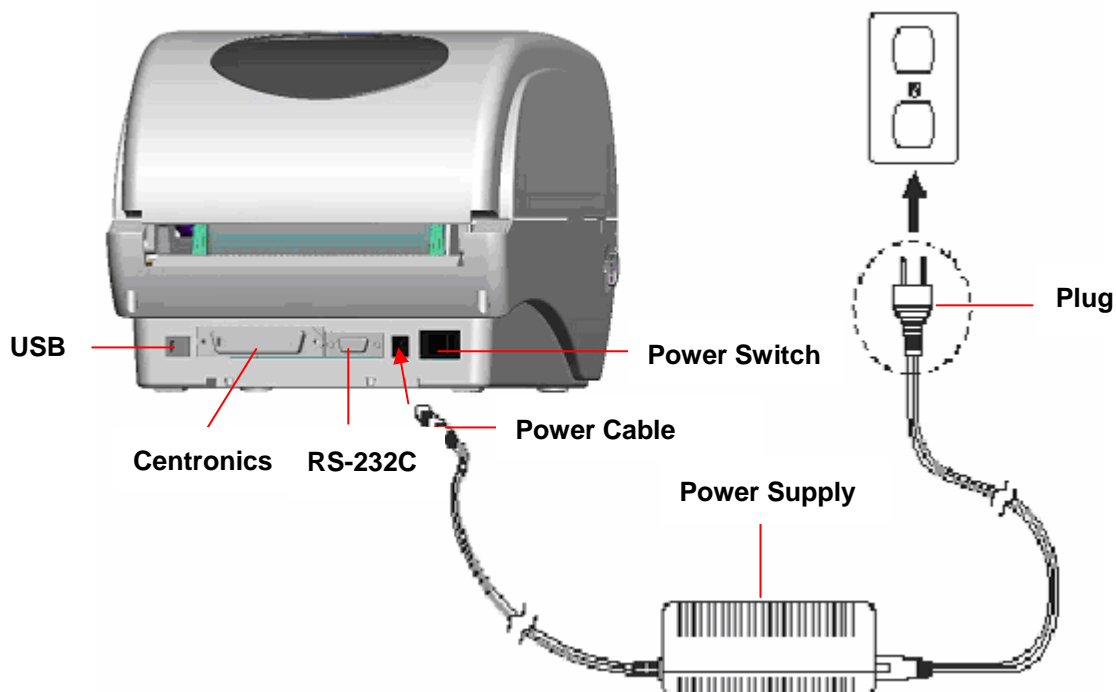


Fig. 3 Attach power supply to printer

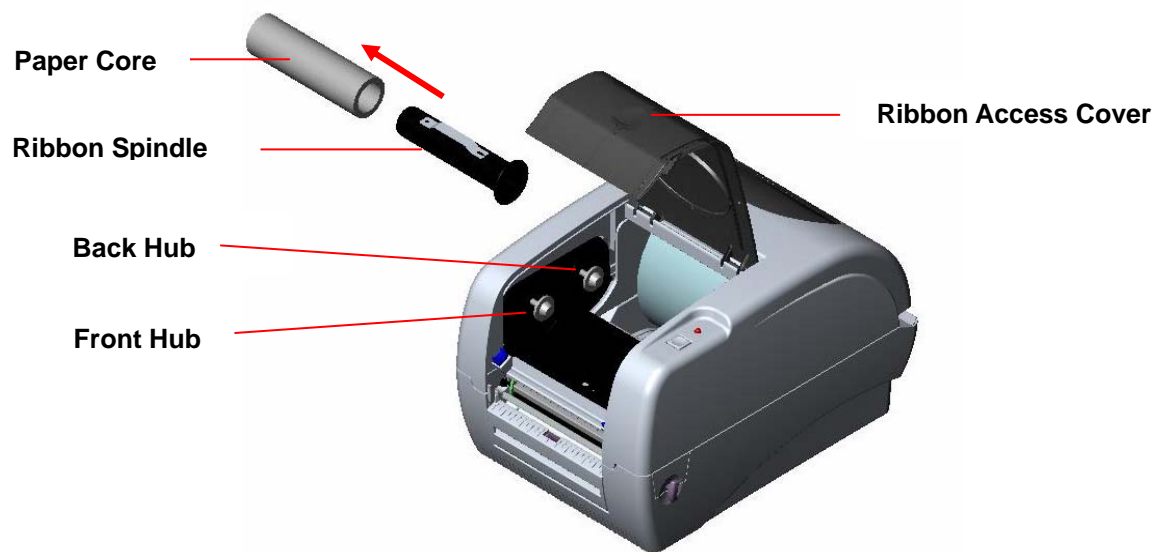
### 3.2 Loading the Ribbon

The printer will detect if the ribbon is installed after turning on power on and it will set printing mode to thermal transfer or direct thermal printing mode automatically. If printer does not detect the ribbon, the ribbon take up motor will be turned off.

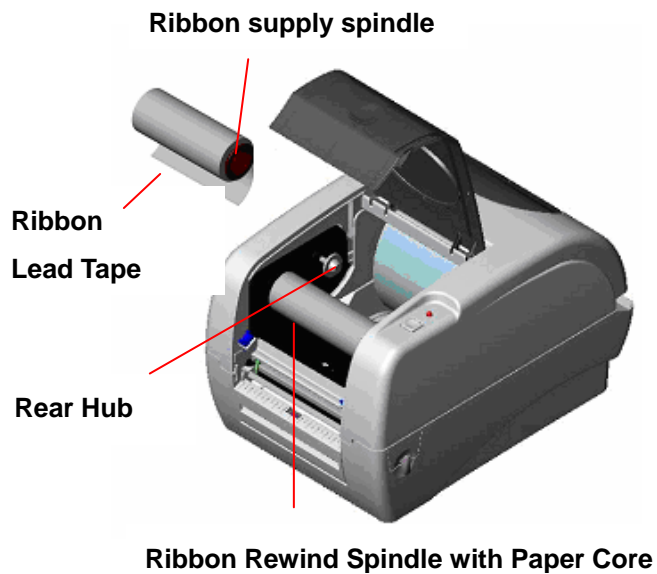
Make sure the printer top cover is engaged properly at both sides prior to powering up the printer.

Please follow the steps below to install the ribbon into printer.

1. Push down on the ribbon access window to unlatch and open the cover.
2. Place a paper core onto the ribbon rewind spindle.
3. Mount the ribbon rewind paper core on the front hubs.
4. Install a ribbon on the ribbon supply spindle.
5. Mount the ribbon supply spindle on the rear hubs.
6. Thread the ribbon leading tape downward pass the print head.
7. Attach the ribbon leader to the ribbon rewind paper core.
8. Rotate the ribbon rewind paper core until the ribbon leader is thoroughly, firmly encompassed by the black section of the ribbon.
9. Close the ribbon access window.



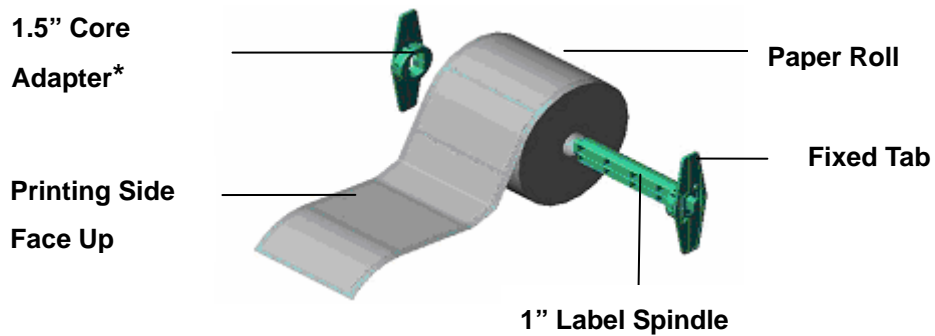
**Fig. 4 Ribbon installation (I)**



**Fig. 5 Ribbon installation (II)**

### 3.3 Loading Label Stock

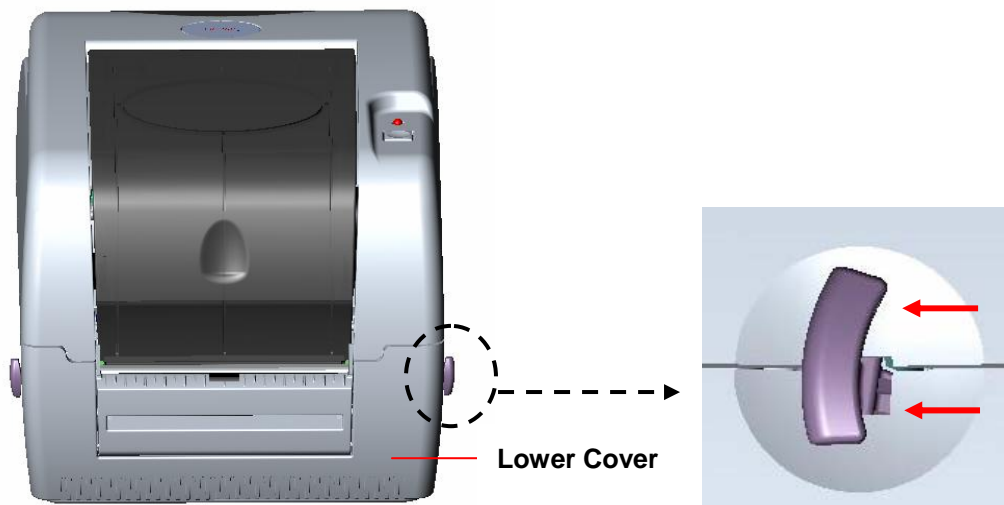
1. Insert a 1" label spindle into a paper roll ( \* If your paper core is 1 inch, remove the 1.5" core adapter from the fixed tab. If label width is 4 inch wide, two fixing tabs are not required. ).



**Fig. 6 Label roll installation (I)**

2. Open the printer's top cover by releasing the green top cover open levers located on each side of the printer and lifting the top cover. A top cover

support at the rear of the printer will hold the printer top cover open.

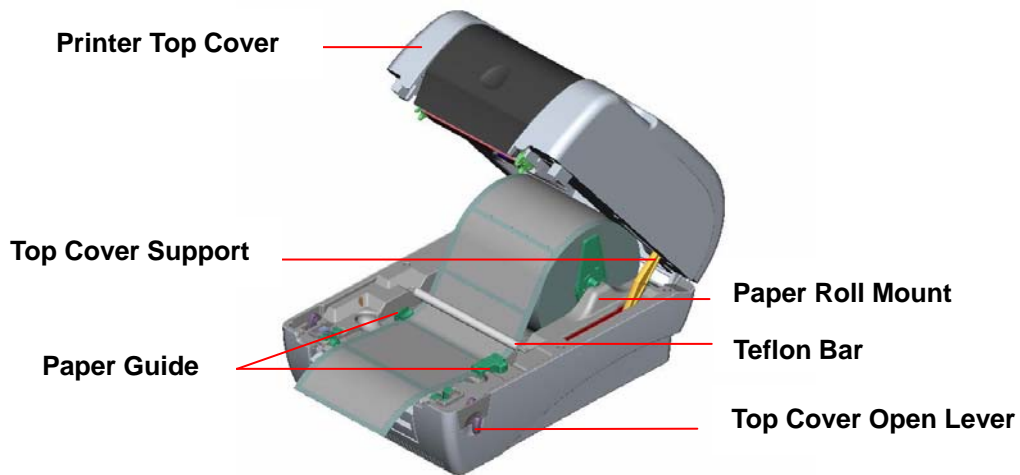


**Fig. 7 Pull the lever to open the cover**

3. Place a roll of paper onto the center of the paper roll mount.
4. Feed the paper, printing side face up, through the Teflon bar and the paper guide and pass over the platen.
5. Adjust the green center-biased paper guides to slightly touch the edges of the label backing.
6. To close the printer top cover, lift the cover to the ultimate open angle then use both hands to close the cover gently. Close the printer top cover slowly and make sure the cover latches securely.

**Note:**

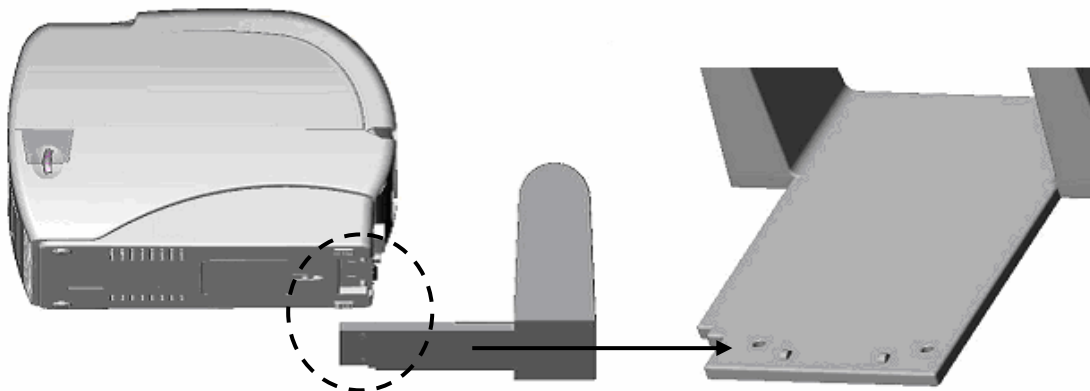
1. ***Make sure hands are not placed between printer top cover and lower cover when close the top cover.***
2. ***Do not free fall the top cover.***
3. ***Failure to securely close and lock the cover will result in poor print quality.***



**Fig. 8 Label installation (II)**

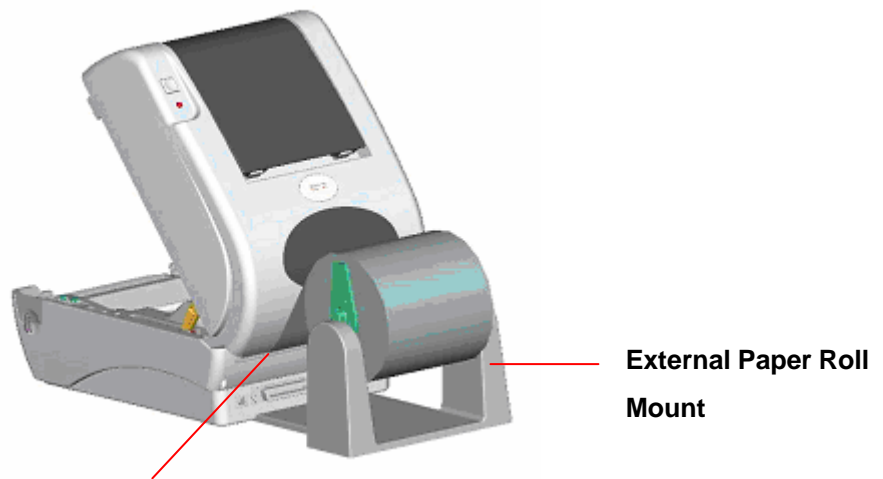
### 3.4 External Label Roll Mount Installation (Option)

1. Attach an external paper roll mount on the bottom of the printer.



**Fig. 9 Attach the external roll mount to the printer**

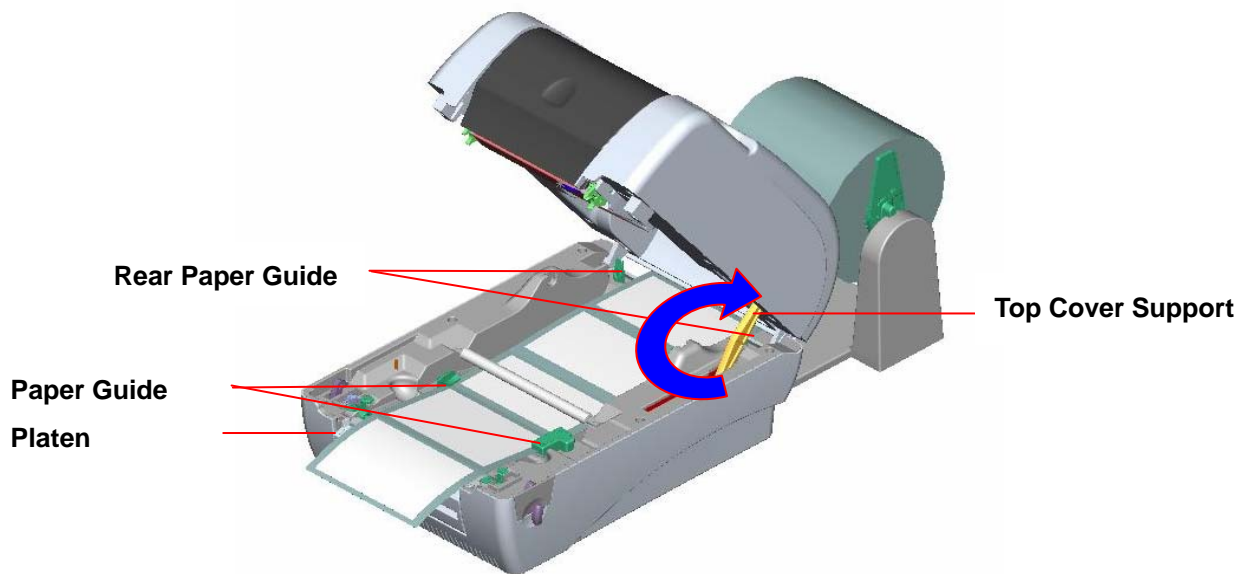
1. Open the printer top cover by releasing the top cover open levers. The top cover support will hold the printer top cover.
2. Install a roll of paper on the external paper roll mount.
3. Feed the paper to the external paper feed opening through the rear paper guide.



**External Paper Feed Opening**

**Fig. 10 External roll mount label installation (I)**

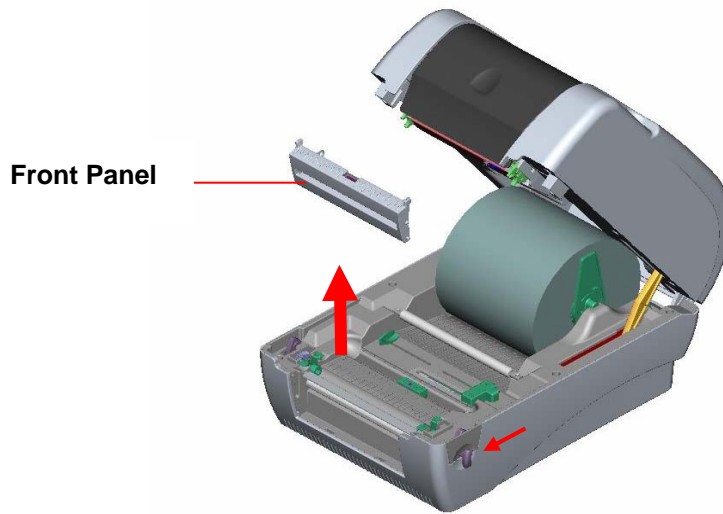
4. Feed the paper, printing side face up, through the paper guide and pass over the platen.
5. Adjust the paper guides to fit the paper width.
6. Close the printer top cover by lifting the top cover to the maximum opening angle then push down the top cover gently.



**Fig. 11 External roll mount label installation (II)**

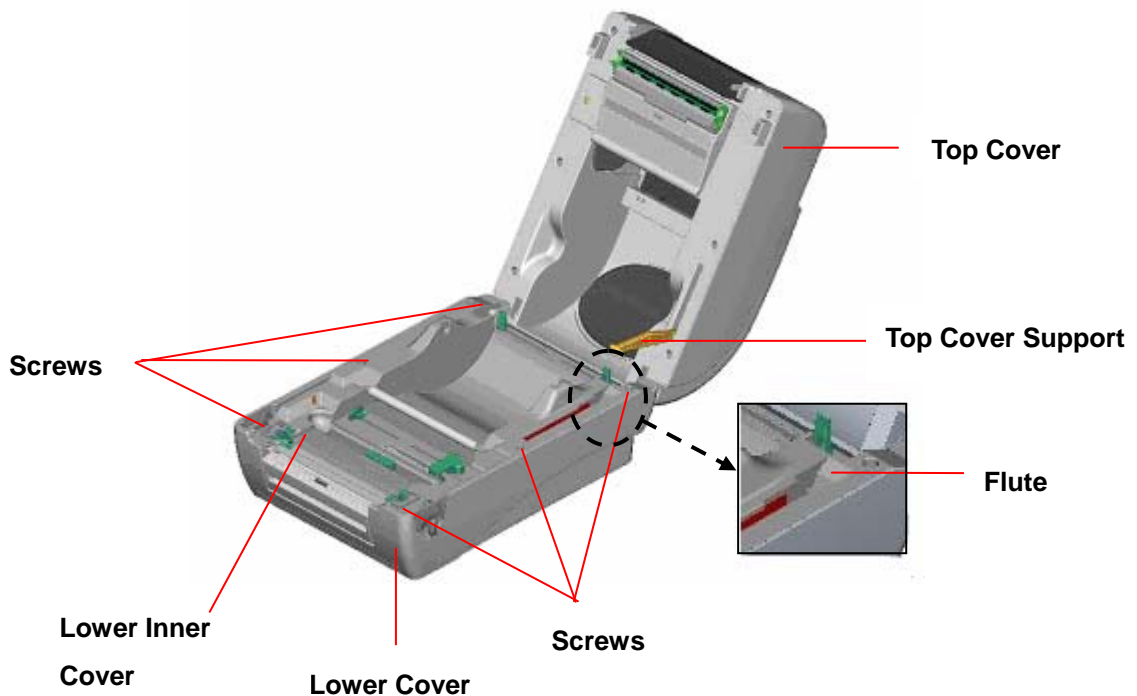
### 3.5 Peel-off Module Installation (Option)

1. Open the top cover and remove the front panel from the printer.



**Fig. 12 Remove the front panel**

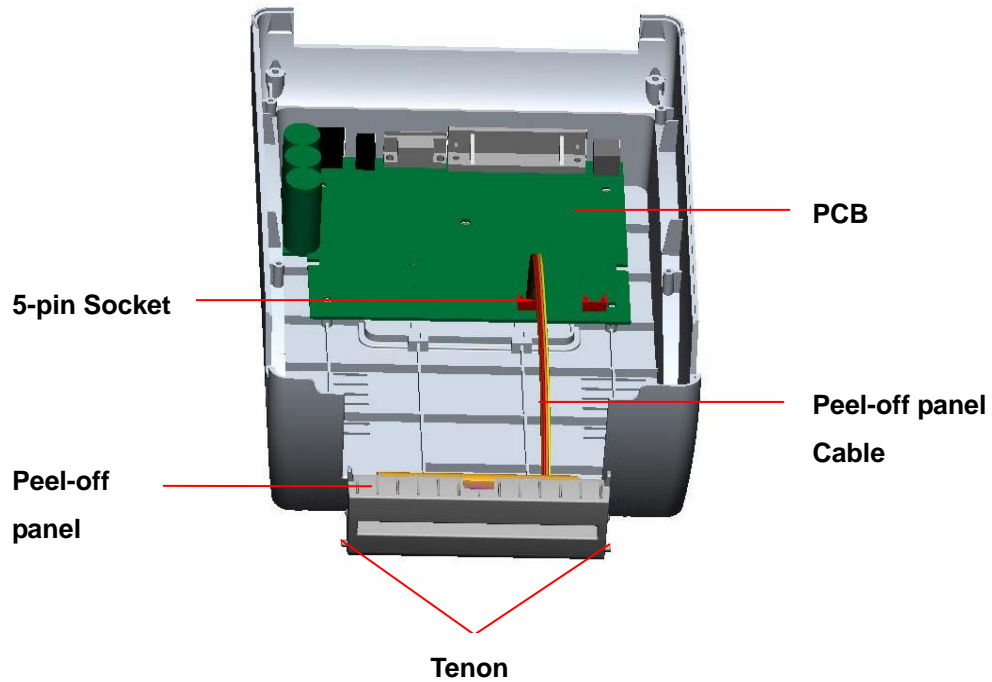
2. Open the top cover and hold it and push down and push backward the top cover support then push backward the top cover.
3. Use a screwdriver to screw off 6 screws on the lower inner cover.



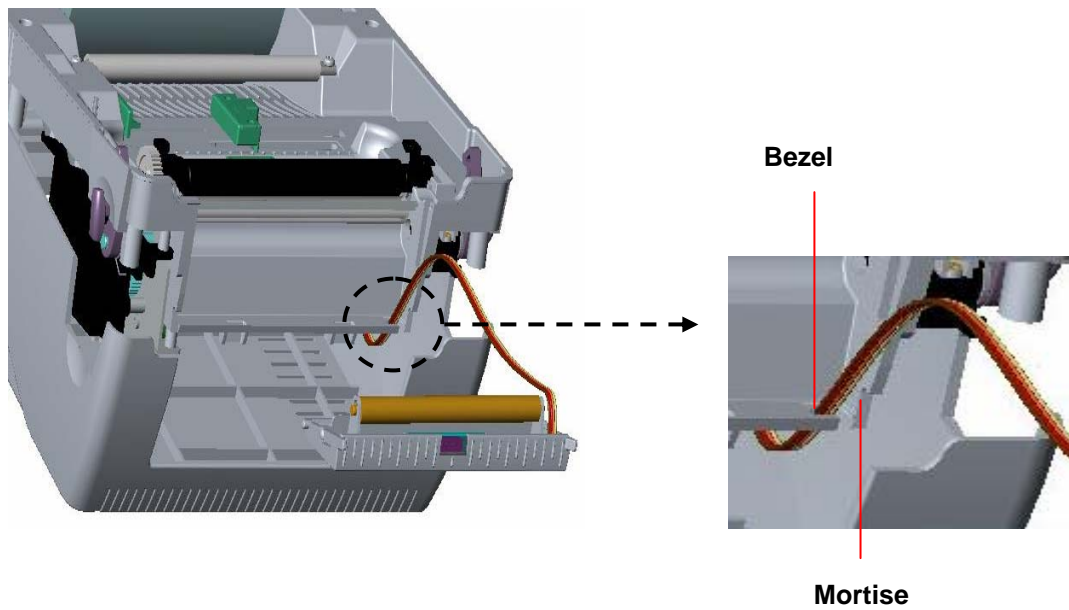
**Fig. 13 Remove 6 screws from lower inner cover**

4. Upside down the printer. Remove two screws at the hinge and remove one

- screw at memory card cover.
5. Hold the lower cover to lift up the top cover open levers to separate the lower inner cover and the lower cover.
  6. Arrange the cable through the bezel. Connect the peel-off panel cable to the 5-pin socket on printer PCB.

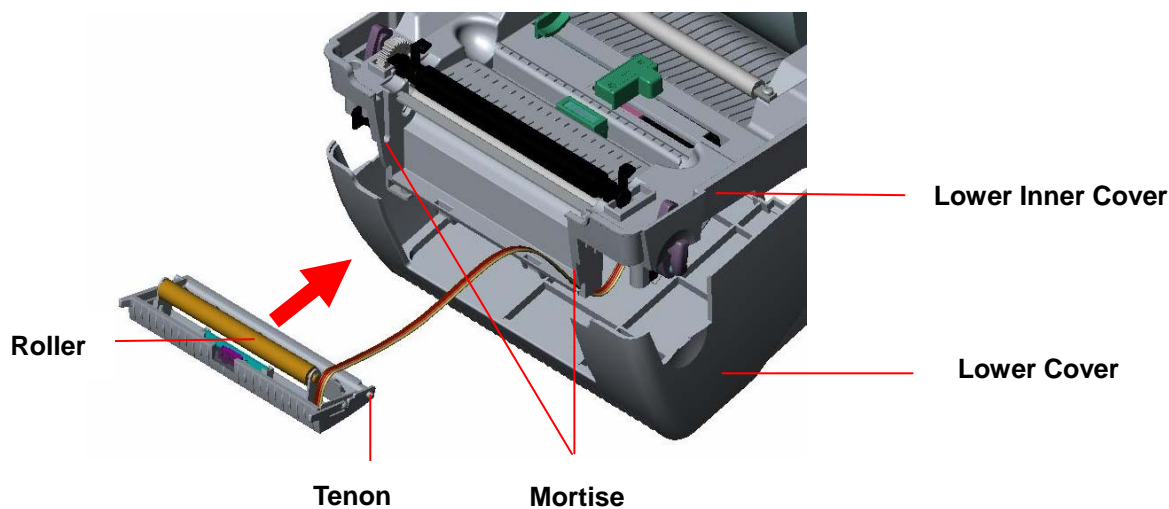


**Fig. 14 Connect peel-off sensor cable to main board**



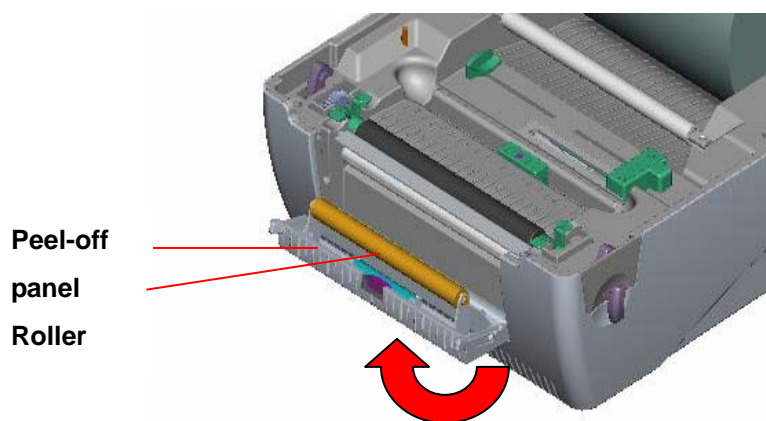
**Fig. 15 Peel-off sensor cable installation**

7. Insert the peel-off tenons into the lower inner cover mortises until tenons snap into places.



**Fig. 16 Peel-off panel installation (I)**

8. Arrange the lower inner cover back to the lower cover.



**Fig. 17 Peel-off panel installation (II)**

9. Lift up the peel-off panel to the lower cover to close it.
10. Use a screwdriver to screw down whole screws on the lower inner cover and the lower cover.
11. Close the top cover by arranging the top cover support back to the flute and push it forward then close the top cover slowly.

### 3.5.1 Loading the Paper in Peel-off Mode

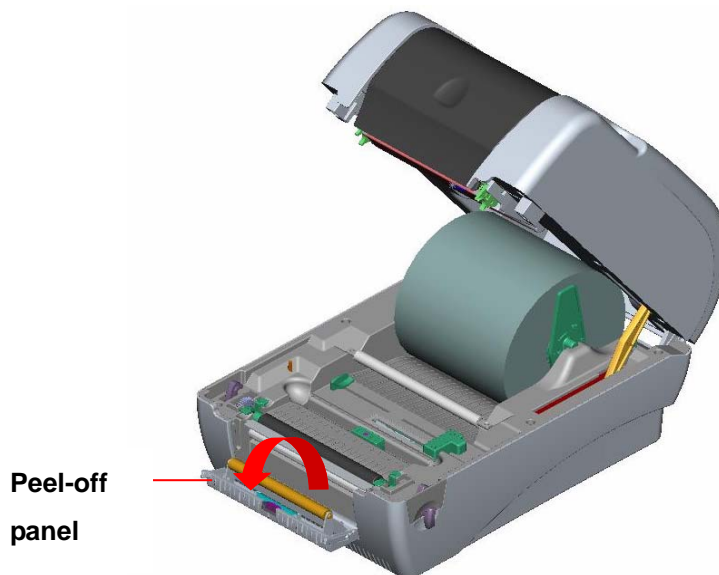
**Note: Both thermal paper and plain paper apply for peel-off function but neither PVC nor vynle work at peel-off function.**

1. Insert a 1" label spindle into a paper roll.
2. Open the printer top cover by pulling the top cover open levers. The top cover support will hold the printer top cover.



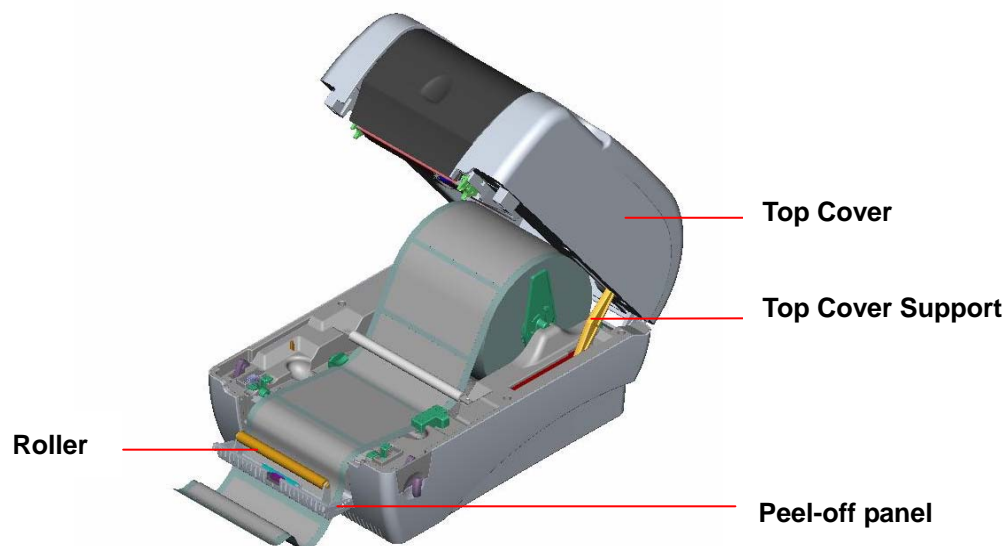
**Fig. 18 Open the top cover**

3. Install the paper roll on the paper roll mount.
4. Open the peel-off panel by pulling it out.



**Fig. 19 Open the peel-off panel**

5. Feed the paper, printing side facing up, through the paper guide and pass over the platen.
6. Lead the paper through the backing paper opening, beneath the roller, and tear off one piece of the label.
7. Adjust the paper guide by removing left or right to fit the paper width.



**Fig. 20 Lead the paper through the backing paper opening, beneath the roller**

8. Push the peel-off panel back to the printer.
9. Close the top cover by lifting up the top cover support and close the top cover slowly.

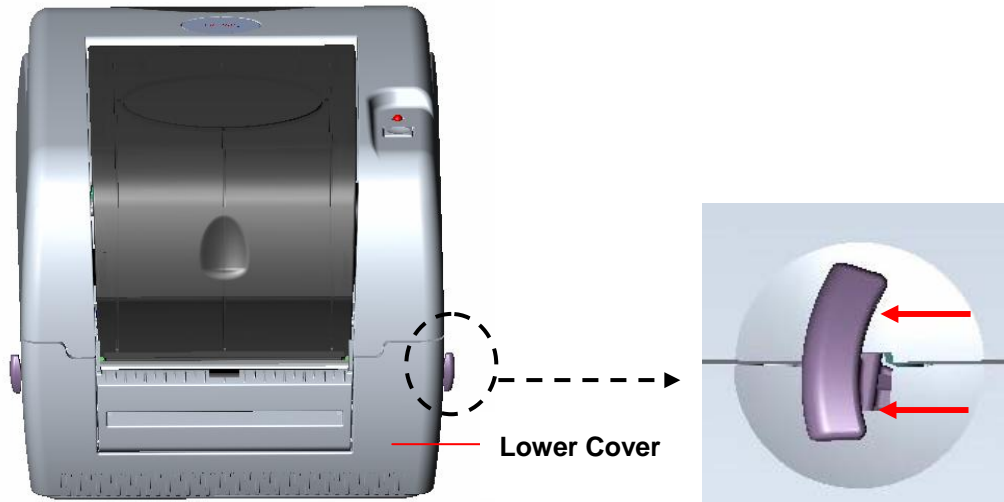
**Note: Pull the label outward tightly after closing the top cover.**



**Fig. 21 Complete label installation for peel-off mode**

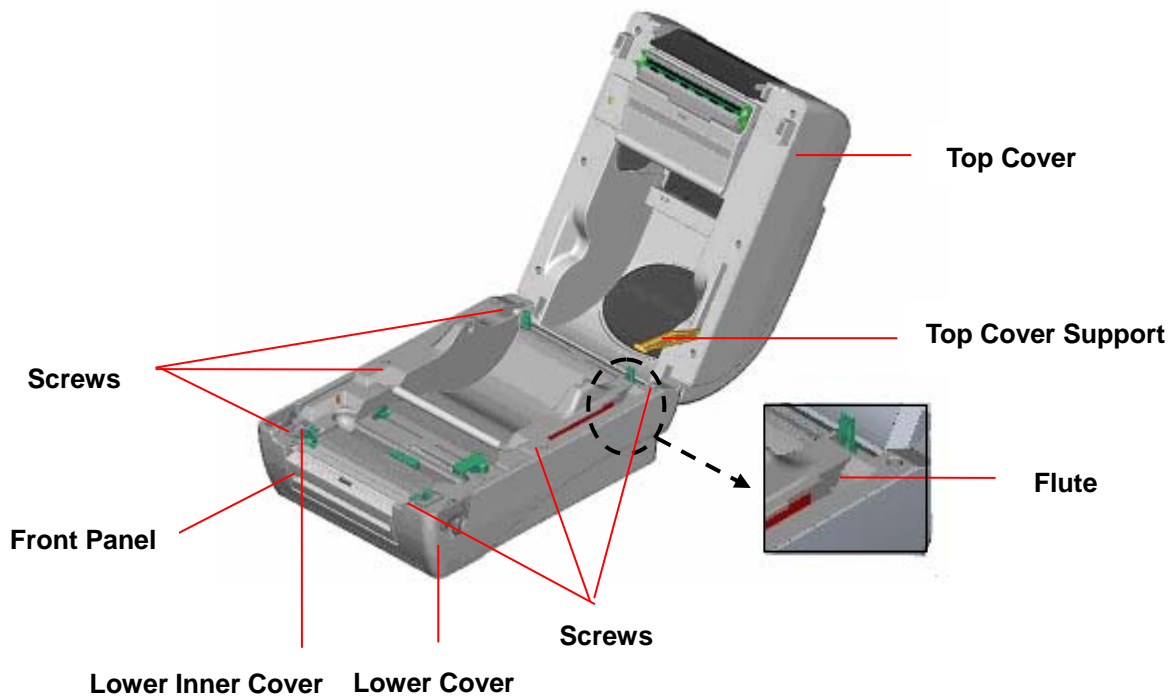
### 3.6 Cutter Module Installation (Option)

1. Pull the top cover open levers to open the top cover.
2. Remove the front panel from the lower cover.



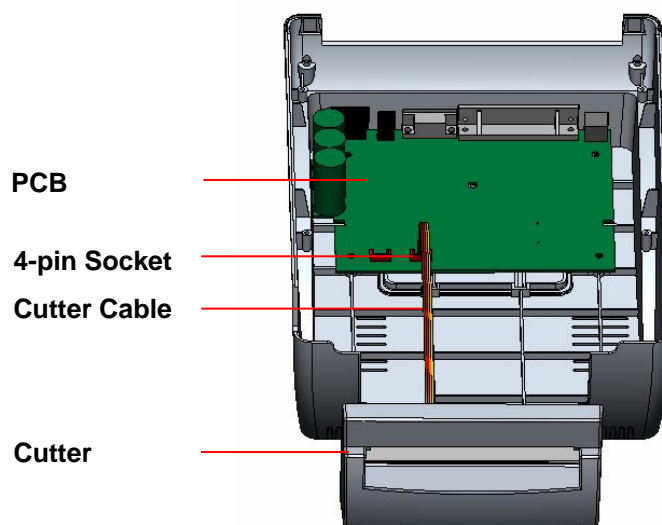
**Fig. 22 Pull the lever to open the cover**

3. Open the top cover and hold it and push down and push backward the top cover support then push backward the top cover.
4. Use a screwdriver to screw off 6 **screws** on the **lower inner cover**.

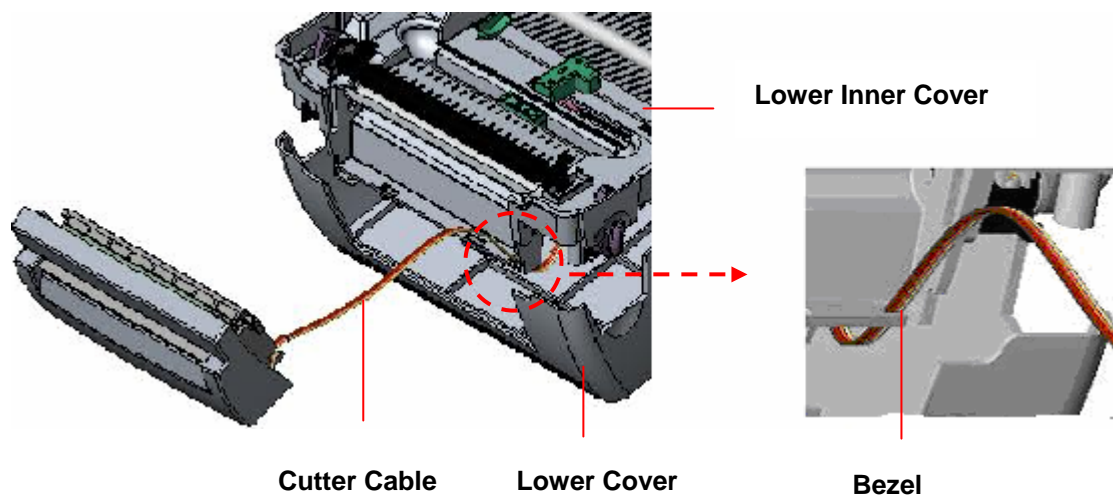


**Fig. 23 Remove 6 screws from lower inner cover**

5. Place the printer upside down and unscrew the two screws of the **hinge holder** on the lower cover.
6. Unscrew the screw of the memory card cover and remove the memory card cover. Plug in the cutter driver IC at U14(TTP-245/343) / U30(TTP-245/343 Plus) socket on the main board.
7. Use both thumbs to hold the lower cover and index fingers to lift up the top cover open levers to separate the lower inner cover and the lower cover.
8. Arrange the cable through the bezel. Connect the cutter module cable to the 4-pin socket on printer PCB.

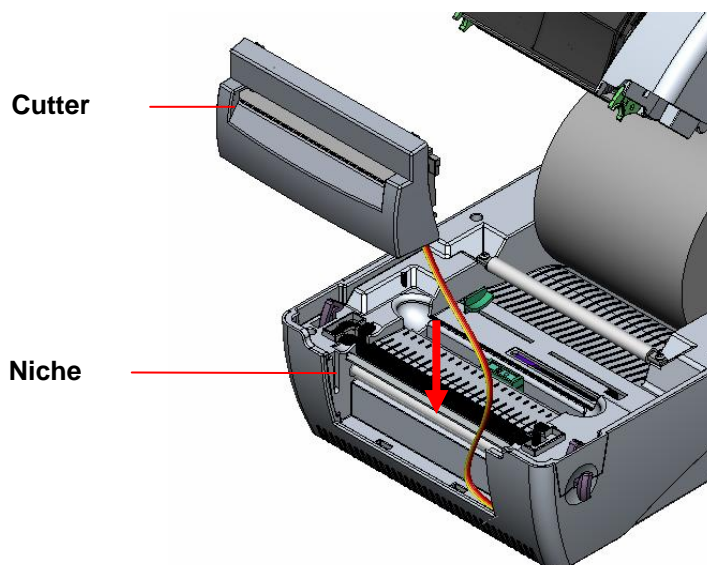


**Fig. 24 Cutter module installation**



**Fig. 25 Cutter module cable arrangement**

9. Arrange the lower inner cover back to the lower cover.
10. Install the cutter into the niches of the printer.

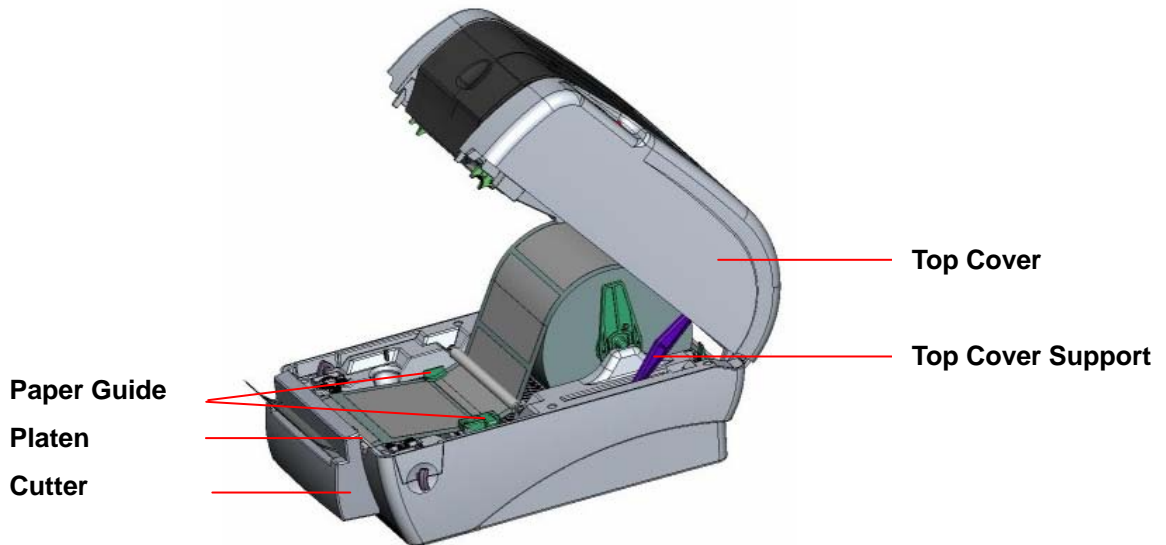


**Fig. 26 Cutter module installation**

11. Use a screwdriver to screw whole screws on the lower inner cover and the lower cover.
12. Close the top cover by arranging the top cover support back to the flute and push it forward then close the top cover slowly.

### **3.6.1 Loading Label in Cutter Mode**

1. Insert a 1" label spindle into a paper roll.
2. Open the printer top.
3. Install a paper roll on the paper roll mount.
4. Feed the paper, printing side face up, through the paper guide and pass over the platen.
5. Lead the paper through the cutter paper opening.
6. Adjust the paper guide by removing left or right to fit the paper width.



**Fig. 27 Label installation in cutter mode**

7. Close the top cover by lifting up the top cover support and close the top cover slowly.



**Fig. 28 Complete label installation in cutter mode**

### **3.7 Instructions to Top Cover Operation**

Please take care when opening or closing the printer's top cover by carefully following these instructions.

To Open:

1. When facing the front of the printer pull the cover release levers on both sides of printer towards you.

2. Lift up the top gradually.

There are two stop positions for the top cover. Position 1 and 2 are indicated on the label below.

**Note: To hold the cover open at position 1, you must lift the cover higher than the stopping point at position 1 and gently lower the cover to stop position 1. *DO NOT free fall the top cover!***

3. Fully open the top cover and gently lower it to stop position 2.

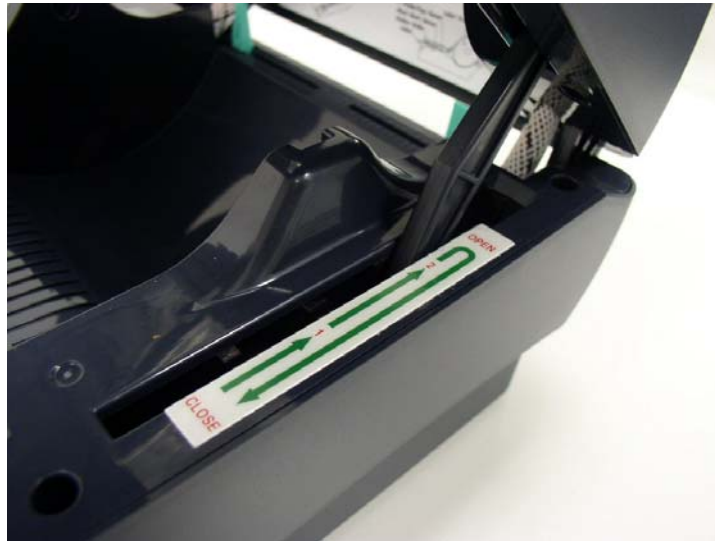


Fig. 1 Top cover support is fixed at position 2

4. To close the cover, lift up the top cover to the ultimate angle then close the top cover gently and it will be kept at a stop position between 1 and 2 for a while. Use both hands to gently push down the top cover to close it and make sure the cover is latched on both sides.

**Note: *DO NOT place your hands between top cover and lower cover while close the top cover!***



Fig. 2 Top cover is fully open and ready to close



Fig. 3 Use both hands to close the top cover


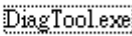
5. ***Do not force the cover!*** If you are not sure if top cover is fixed at stop position, please do not push top cover to close it or the top cover will be damaged.  
Please open the top cover to the ultimate angle to close the top cover again.  
Use both hands to push top cover to close it.

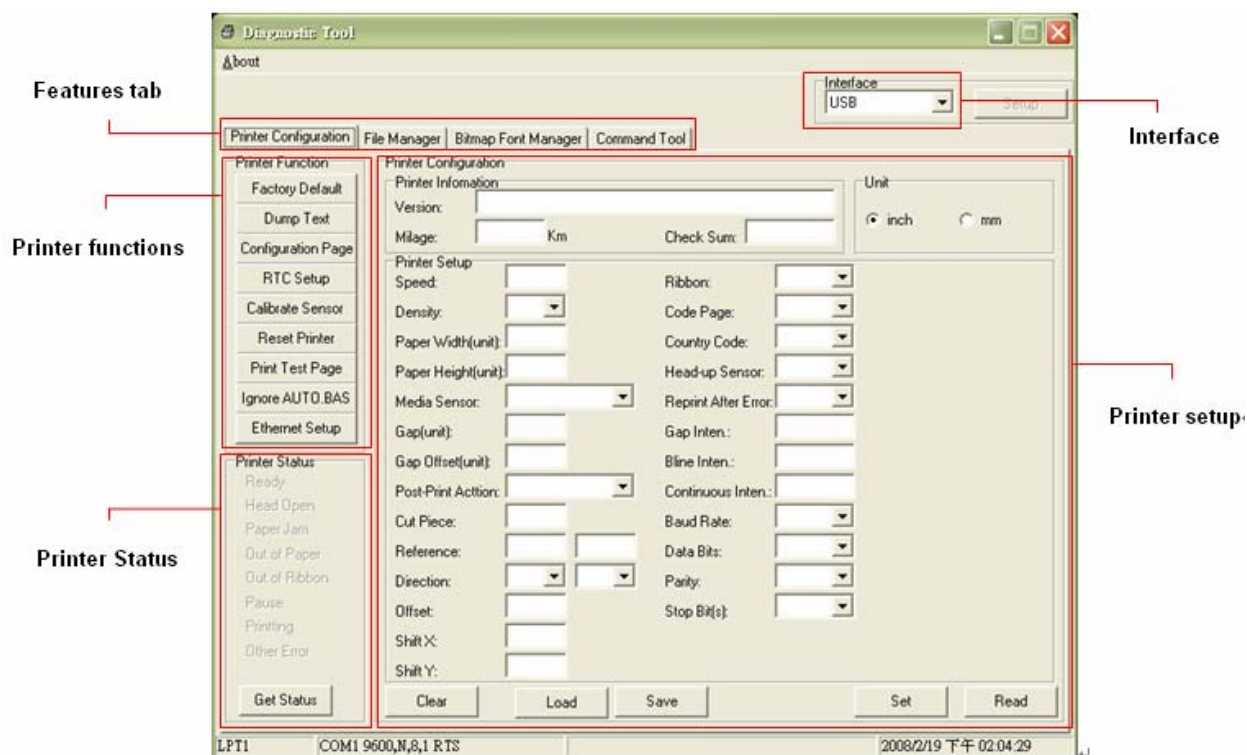
## 3.8 Diagnostic Tool

The Diagnostic Utility is a toolbox that allows users to explore the printer's settings and status; change printer settings; download graphics, fonts, and firmware; create printer bitmap fonts; and to send additional commands to the printer. Using this convenient tool, you can explore the printer status and settings and troubleshoot the printer.

**Note:** This utility works with printer firmware V6.00 and later versions.

### 3.8.1 Start the Diagnostic Tool

1. Double click on the Diagnostic tool icon   to start the software.
2. There are four features (Printer Configuration, File Manager, Bitmap Font Manager, Command Tool) included in the Diagnostic utility.



### 3.8.2 Printer Function (Calibrate sensor, Ethernet setup, RTC setup.....)

1. Select the PC interface connected with bar code printer.
2. Click the “Function” button to setting.
3. The detail functions in the Printer Function Group are listed as below.

	<b>Function</b>	<b>Description</b>
Printer Function Factory Default Dump Text Configuration Page RTC Setup Calibrate Sensor Reset Printer Print Test Page Ignore AUTO.BAS Ethernet Setup	Factory Default	Initialize the printer and restore the settings to factory default.
	Dump Text	To activate the printer dump mode.
	Configuration Page	Print printer configuration.
	RTC Setup	Synchronize printer Real Time Clock with PC.
	Calibrate Sensor	Calibrate the sensor specified in the Printer Setup group media sensor field.
	Reset Printer	Reboot the printer.
	Print Test Page	Print a test page.
	Ignore AUTO.BAS	Ignore the downloaded AUTO.BAS program.
	Ethernet Setup	Setup the IP address, subnet mask, gateway for the on board Ethernet.

**Note:**



For more information about Diagnostic Tool, please refer to the diagnostic utility quick start guide in the CD disk \ Utilities directory.

### 3.9 Install Memory Card

1. Turn the printer upside down.
2. Remove the screw that fixes the **memory card cover**.



3. Plug in the memory card on main board.

TTP-245/343 Model (Option)	TTP-245/343 Plus Model (SD Card)
	

4. Close the memory card cover.

\* Recommended SD card specification.

SD card spec	SD card capacity	Approved SD card manufacturer
V1.0, V1.1	128 MB	SanDisk, Transcend
V1.0, V1.1	256 MB	SanDisk, Transcend, Panasonic
V1.0, V1.1	512 MB	SanDisk, Transcend, Panasonic
V1.0, V1.1	1 GB	SanDisk, Transcend, Panasonic
V2.0 SDHC CLASS 4	4 GB	
V2.0 SDHC CLASS 6	4 GB	SanDisk, Transcend, Panasonic
V1.0, V1.1	microSD 128 MB	Transcend, Panasonic
V1.0, V1.1	microSD 256 MB	Transcend, Panasonic
V1.0, V1.1	microSD 512 MB	Panasonic

V1.0, V1.1	microSD 1 GB	Transcend, Panasonic
V2.0 SDHC CLASS 4	microSD 4 GB	Panasonic
V2.0 SDHC CLASS 6	microSD 4 GB	Transcend
V1.0, V1.1	miniSD 128 MB	Transcend, Panasonic
V1.0, V1.1	miniSD 256 MB	Transcend, Panasonic
V1.0, V1.1	miniSD 512 MB	Transcend, Panasonic
V1.0, V1.1	miniSD 1 GB	Transcend, Panasonic
V2.0 SDHC CLASS 4	miniSD 4 GB	Transcend
V2.0 SDHC CLASS 6	miniSD 4 GB	
<ul style="list-style-type: none"> <li>- The DOS FAT file system is supported for the SD card.</li> <li>- Folders/files stored in the SD card should be in the 8.3 filename format</li> <li>- The miniSD/microSD card to SD card slot adapter is required.</li> </ul>		

## 4. Power on Utilities

There are six power-on utilities to set up and test printer hardware. These utilities are activated by pressing FEED button and by turning on the printer power simultaneously. The utilities are listed as below:

1. Ribbon sensor calibration and Gap or black mark sensor calibration
2. Gap/black mark sensor calibration ; Self-test and dump mode
3. Printer initialization
4. Set black mark sensor as media sensor and calibrate the black mark sensor
5. Set gap sensor as media sensor and calibrate the gap sensor
6. Skip AUTO.BAS

### 4.1 Ribbon and Gap/Black Mark Sensor Calibration

Gap/black mark sensor sensitivity should be calibrated at the following conditions:

1. A brand new printer
2. Change label stock.
3. Printer initialization.

Please follow the steps below to calibrate the ribbon and gap/black mark sensor.

1. Turn off the power switch.
2. Hold on the button then turn on the power switch.
- 3 Release the button when LED becomes **red** and blinking. (Any red will do during the 5 blinks).
  - It will calibrate the ribbon sensor and gap/black mark sensor sensitivity.
  - The LED color will be changed as following order :  
Amber → **red (5 blinks)** → amber (5 blinks) → green (5 blinks) → green/amber (5 blinks) → red/amber (5 blinks) → solid green

#### Note:

**Please select gap or black mark sensor by sending GAP or BLINE command to printer prior to calibrate the sensor.**

**For more information about GAP and BLINE command, please refer to TSPL2 programming manual.**

## 4.2 Gap/Black Mark Calibration, Self-test and Dump

### Mode

While calibrate the gap/black mark sensor, printer will measure the label length, print the internal configuration (self-test) on label and then enter the dump mode. To calibrate gap or black mark sensor, depends on the sensor setting in the last print job.

Please follow the steps below to calibrate the sensor.

1. Turn off the power switch.
2. Hold on the button then turn on the power switch.
3. Release the button when LED becomes **amber** and blinking. (Any amber will do during the 5 blinks).
  - The LED color will be changed as following order.  
Amber → red (5 blinks) → **amber (5 blinks)** → green (5 blinks) → green/amber (5 blinks) → red/amber (5 blinks) → solid green
4. It calibrates the sensor and measures the label length and prints internal settings then enter the dump mode.

#### Note:

**Please select gap or black mark sensor by Diagnostic tool or by GAP or BLINE command prior to calibrate the sensor.**

**For more information about GAP and BLINE command, please refer to TSPL2 programming manual.**



## Dump mode

Printer will enter dump mode after printing printer configuration. In the dump mode, all characters will be printed in 2 columns as following. The left side characters are received from your system and right side data are the corresponding hexadecimal value of the characters. It allows users or engineers to verify and debug the program.

ASCII Data →	<pre> SPEED 2.0      53 50 45 45 44 20 32 2E 30 0D DENSITY 8     0A 44 45 4E 53 49 54 59 20 38 SET PEEL      0D 0A 53 45 54 20 50 45 45 4C OFF DIRE      20 4F 46 46 0D 0A 44 49 52 45 CTION 0 G     43 54 49 4F 4E 20 30 0D 0A 47 AP 3.00 mm    41 50 20 33 2E 30 30 20 6D 6D .0.00 mm      2C 30 2E 30 30 20 6D 6D 0D 0A REFERENCE     52 45 46 45 52 45 4E 43 45 20 0.0 SET C     30 2C 30 0D 0A 53 45 54 20 43 UTTER OFF     55 54 54 45 52 20 4F 46 46 0D SIZE 100.     0A 53 49 5A 45 20 31 30 30 2E 02 mm,65.0    30 32 20 6D 6D 2C 36 35 2E 30 4 mm CLS      34 20 6D 6D 0D 0A 43 4C 53 0D BARCODE 1     0A 42 41 52 43 4F 44 45 20 31 44,149,"39    34 34 2C 31 34 39 2C 22 33 39 ",120,1,0,    22 2C 31 32 30 2C 31 2C 30 2C 2,6,"57114   32 2C 36 2C 22 35 37 31 31 34 38T" PRIN     33 38 54 22 0D 0A 50 52 49 4E T 1,1 SPE     54 20 31 2C 31 0D 0A 53 50 45 ED 2.0 DE     45 44 20 32 2E 30 0D 0A 44 45 NSITY 8 S     4E 53 49 54 59 20 38 0D 0A 53  ET PEEL OF    45 54 20 50 45 45 4C 20 4F 46 F DIRECTI     46 0D 0A 44 49 52 45 43 54 49 ON 0 GAP      4F 4E 20 30 0D 0A 47 41 50 20 3.00 mm,0.    33 2E 30 30 20 6D 6D 2C 30 2E 00 mm REF     30 30 20 6D 6D 0D 0A 52 45 46 ERENCE 0.0    45 52 45 4E 43 45 20 30 2C 30 SET CUTT      0D 0A 53 45 54 20 43 55 54 54 ER OFF SI     45 52 20 4F 46 46 0D 0A 53 49 ZE 100.02     5A 45 20 31 30 30 2E 30 32 20 mm,65.04 m    6D 6D 2C 36 35 2E 30 34 20 6D m CLS BA      6D 0D 0A 43 4C 53 0D 0A 42 41 RCODE 144.    52 43 4F 44 45 20 31 34 34 2C 149,"39",1    31 34 39 2C 22 33 39 22 2C 31 20,1,0,2,6    32 30 2C 31 2C 30 2C 32 2C 36 ,"5711438T    2C 22 35 37 31 31 34 33 38 54 " PRINT 1     22 0D 0A 50 52 49 4E 54 20 31 .1            2C 31 0D 0A </pre>	→ Hex decimal data related to left column of ASCII data
--------------	---	---

Fig. 30 Dump mode printout

### Note:

Turn off / on the power to resume printer for normal printing.

## 4.3 Printer Initialization

Printer initialization is used to clear DRAM and restore printer settings to defaults. The only one exception is ribbon sensitivity, which will not be restored to default.

Printer initialization is activated by the following procedures.

1. Turn off the power switch.
2. Hold on the button then turn on the power switch.
3. Release the button when LED turns **green** after 5 amber blinks. (Any green will do during the 5 blinks).
  - The LED color will be changed as following:  
Amber → red (5 blinks) → amber (5 blinks) → **green (5 blinks)** → green/amber (5 blinks) → red/amber (5 blinks) → solid green

Printer configuration will be restore to defaults as below after initialization.

Parameter	Default setting
Speed	203DPI :127 mm/sec (5 ips) 300DPI: 76 mm/sec (3 ips)
Density	8
Label Width	4" (101.6 mm)
Label Height	4" (101.6 mm)
Sensor Type	Gap sensor
Gap Setting	0.12" (3.0 mm)
Print Direction	0
Reference Point	0,0 (upper left corner)
Offset	0
Tear Mode	On
Peel off Mode	Off
Cutter Mode	Off
Serial Port Settings	9600 bps, none parity, 8 data bits, 1 stop bit
Code Page	850
Country Code	001
Clear Flash Memory	No
IP Address	DHCP

**Note :**

**Always do gap/black mark sensor calibration after printer initialization.**

## 4.4 Set Black Mark Sensor as Media Sensor and Calibrate the Black Mark Sensor

Please follow the steps as below.

1. Turn off the power switch.
2. Hold on the button then turn on the power switch.
3. Release the button when LED turns **green/amber** after 5 green blinks. (Any green/amber will do during the 5 blinks).
  - The LED color will be changed as following:  
Amber → red (5 blinks) → amber (5 blinks) → green (5 blinks) → **green/amber (5 blinks)** → red/amber (5 blinks) → solid green

## 4.5 Set Gap Sensor as Media Sensor and Calibrate the Gap Sensor

Please follow the steps as below.

1. Turn off the power switch.
2. Hold on the button then turn on the power switch.
3. Release the button when LED turns **red/amber** after 5 green/amber blinks. (Any red/amber will do during the 5 blinks).
  - The LED color will be changed as following:  
Amber → red (5 blinks) → amber (5 blinks) → green (5 blinks) → green/amber (5 blinks) → **red/amber (5 blinks)** → solid green

## 4.6 Skip AUTO.BAS

TSPL2 programming language allows user to download an auto execution file to flash memory. Printer will run the AUTO.BAS program immediately when turning on printer power. The AUTO.BAS program can be interrupted without running the program by the power-on utility.

Please follow the procedures below to skip an AUTO.BAS program.

1. Turn off printer power.
2. Press the FEED button and then turn on power.
3. Release the FEED button when LED becomes **solid green**.
  - The LED color will be changed as following:  
Amber → red (5 blinks) → amber (5 blinks) → green (5 blinks) →  
green/amber (5 blinks) → red/amber (5 blinks) → **solid green**
4. Printer will be interrupted to run the AUTO.BAS program.

## 5. Maintenance

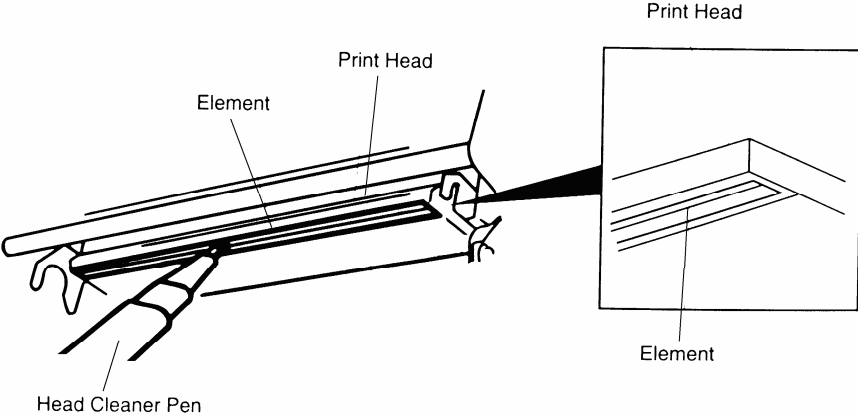
### 5.1 Cleaning

This session presents the clean tools and methods to maintain your printer.

1. Please use one of following material to clean the printer.

- Cotton swab (Head cleaner pen)
- Lint-free cloth
- Vacuum / Blower brush
- 100% ethanol

2. The cleaning process is described as following

Printer Part	Method	Interval
<p><b>Print Head</b></p>	<p>1. Always turn off the printer before cleaning the print head.            2. Allow the print head to cool for a minimum of one minute.            3. Use a cotton swab (Head cleaner pen) and 100% ethanol to clean the print head surface.</p>	<p>Clean the print head when changing a new label roll</p>
 <p>The diagram illustrates the cleaning process for the print head. It shows a hand holding a 'Head Cleaner Pen' and applying it to the 'Print Head' surface. The 'Print Head' is shown in a perspective view, with the 'Element' labeled. An inset box provides a closer view of the 'Print Head' and 'Element'.</p>		
<p><b>Platen Roller</b></p>	<p>1. Turn the power off.            2. Rotate the platen roller and wipe it thoroughly with 100% ethanol and a cotton swab, or lint-free cloth.</p>	<p>Clean the platen roller when changing a new label roll</p>
<p><b>Tear Bar/Peel Bar</b></p>	<p>Use the lint-free cloth with 100% ethanol to wipe it.</p>	<p>As needed</p>
<p><b>Sensor</b></p>	<p>Compressed air or vacuum</p>	<p>Monthly</p>
<p><b>Exterior</b></p>	<p>Wipe it with water-dampened</p>	<p>As needed</p>

	cloth	
<b>Interior</b>	Brush or vacuum	As needed

**Note:**

- Do not touch printer head by hand. If you touch it careless, please use ethanol to clean it.
- Please use 100% Ethenol. DO NOT use medical alcohol, which may damage the printer head.
- Regularly clean the print head and supply sensors once change a new ribbon to keep printer performance and extend printer life.

## 6. Troubleshooting

The following guide lists the most common problems that may be encountered when operating this bar code printer. If the printer still does not function after all suggested solutions have been invoked, please contact the Customer Service Department of your purchased reseller or distributor for assistance.

### 6.1 LED Status

This section lists the common problems that according to the LED status and other problems you may encounter when operating the printer. Also, it provides solutions.

LED Status / Color	Printer Status	Possible Cause	Recovery Procedure
OFF	No response	No power	<ul style="list-style-type: none"> <li>* Turn on the power switch.</li> <li>* Check if the green LED is lit on power supply. If it is not lit on, power supply is broken.</li> <li>* Check both power connections from the power cord to the power supply and from the power supply to the printer power jack if they are connected securely.</li> </ul>
Solid Green	ON	The printer is ready to use	* No action necessary.
Green with blinking	Pause	The printer is paused	* Press the FEED button to resume for printing.
Red with blinking	Error	The out of label or ribbon or the printer setting is not correct	<ol style="list-style-type: none"> <li>1. Out of label or ribbon               <ul style="list-style-type: none"> <li>* Load a roll of label and follow the instructions in loading the media then press the FEED button to resume for printing.</li> <li>* Load a roll of ribbon and follow the instructions in loading the ribbon then press the FEED button to resume for printing.</li> </ul> </li> <li>2. Printer setting is not correct               <ul style="list-style-type: none"> <li>* Initialize the printer by instructions in</li> </ul> </li> </ol>

			"Power on Utility" or "Diagnostic Tool".
--	--	--	--

**Note:**

Printer status can be easily shown on the Diagnostic Tool. For more information about the Diagnostic Tool, please refer to the instruction in the software CD disk.

## 6.2 Print Quality

Problem	Possible Cause	Recovery Procedure
<b>Not Printing</b>	Check if interface cable is well connected to the interface connector.	Re-connect cable to interface.
	The serial port cable pin configuration is not pin to pin connected.	Please replace the cable with pin to pin connected.
	The serial port setting is not consistent between host and printer.	Please reset the serial port setting.
	The port specified in the Windows driver is not correct.	Select the correct printer port in the driver.
	The Ethernet IP, subnet mask, gateway is not configured properly.	Configure the IP, subnet mask and gateway.
<b>No print on the label</b>	Label or ribbon loaded not correctly.	Follow the instructions in loading the media or loading the ribbon.
	Ribbon run out.	Loading the ribbon.
<b>Continuous feeding labels</b>	The printer setting may go wrong.	Please do the initialization and gap/black mark calibration.
<b>Paper Jam</b>	Gap/black mark sensor sensitivity is not set properly (sensor sensitivity is not enough)	Calibrate the gap/black mark sensor.
	Make sure label size is set properly.	Set label size exactly as installed paper in the labeling software or program.
	Labels may be stuck inside the printer mechanism near the sensor area.	Remove the stuck label.
<b>Poor Print Quality</b>	Top cover is not closed properly.	Close the top cover completely and make sure the right side and left side levers are latched properly

	Check if supply is loaded correctly.	Reload the supply.
	Ribbon and media are incompatible.	Change the ribbon or label combination.
	Check if dust or adhesives are accumulated on the print head.	Clean the print head.
	Check if print density is set properly.	Adjust the print density and print speed.
	Check print head test pattern if head element is damaged.	Run printer self-test and check the print head test pattern if there is dot missing in the pattern.

## 7. LED and Button Operation

### 7.1 LED

LED Color	Description
Green/ Solid	This illuminates that the power is on and the device is ready to use.
Green/ Flash	This illuminates that the system is downloading data from PC to memory and the printer is paused.
Amber	This illuminates that the system is clearing data from printer.
Red / Solid	This illuminates printer head open, cutter error.
Red / Flash	This illuminates a printing error, such as head open, paper empty, paper jam, ribbon empty, or memory error etc.

### 7.2 Button Operation

<b>Feed</b>	<ul style="list-style-type: none"> <li>● Press the button when the LED is <b>green</b>.               <ul style="list-style-type: none"> <li>■ It feeds the label to the beginning of the next label.</li> </ul> </li> </ul>
<b>Pause</b>	<ul style="list-style-type: none"> <li>● Press the feed button during printing               <ul style="list-style-type: none"> <li>■ The printing job is suspended.</li> </ul> </li> </ul>
<b>Ribbon Sensor and Gap/Black Mark Sensor Calibration</b>	<ol style="list-style-type: none"> <li>1. Turn off the power switch.</li> <li>2. Hold on the button then turn on the power switch.</li> <li>3 Release the button when LED becomes <b>red</b> and blinking. (Any red will do during the 5 blinks).               <ul style="list-style-type: none"> <li>■ It will calibrate the ribbon sensor and gap/black mark sensor sensitivity.</li> <li>■ The LED color will be changed as following order : Amber → <b>red (5 blinks)</b> → amber (5 blinks) → green (5 blinks) → green/amber (5 blinks) → red/amber (5 blinks) → solid green</li> </ul> </li> </ol> <p><b>Note:</b> Please select gap or black mark sensor by <b>GAP</b> or <b>BLINE</b> command prior to calibrate the sensor. For more information about <b>GAP</b> and <b>BLINE</b> command, please refer to <b>TSPL2</b> programming manual.</p>

<p><b>Gap/Black Mark Sensor Calibration, Label Length Measurement, Self Test and enter Dump Mode</b></p>	<ol style="list-style-type: none"> <li>1. Turn off the power switch.</li> <li>2. Hold on the button then turn on the power switch.</li> <li>3. Release the button when LED becomes <b>amber</b> and blinking. (Any amber will do during the 5 blinks). <ul style="list-style-type: none"> <li>■ The LED color will be changed as following order. Amber → red (5 blinks) → <b>amber (5 blinks)</b> → green (5 blinks) → green/amber (5 blinks) → red/amber (5 blinks) → solid green</li> <li>■ It calibrates the sensor and measures the label length and prints internal settings then enter the dump mode.</li> </ul> </li> </ol> <p><b>Note:</b> Please select gap or black mark sensor by <b>GAP</b> or <b>BLINE</b> command prior to calibrate the sensor. For more information about <b>GAP</b> and <b>BLINE</b> command, please refer to <b>TSPL2 programming manual</b>.</p>
<p><b>Printer Initialization</b></p>	<ol style="list-style-type: none"> <li>1. Turn off the power switch.</li> <li>2. Hold on the button then turn on the power switch.</li> <li>3. Release the button when LED turns <b>green</b> after 5 amber blinks. (Any green will do during the 5 blinks). <ul style="list-style-type: none"> <li>■ The LED color will be changed as following: Amber → red (5 blinks) → amber (5 blinks) → <b>green (5 blinks)</b> → green/amber (5 blinks) → red/amber (5 blinks) → solid green</li> </ul> </li> </ol> <p><b>Note:</b> Always do gap/black mark sensor calibration after printer initialization.</p>
<p><b>Set Black Mark Sensor as Media Sensor and Calibrate the Black Mark Sensor</b></p>	<ol style="list-style-type: none"> <li>1. Turn off the power switch.</li> <li>2. Hold on the button then turn on the power switch.</li> <li>3. Release the button when LED turns <b>green/amber</b> after 5 green blinks. (Any green/amber will do during the 5 blinks). <ul style="list-style-type: none"> <li>■ The LED color will be changed as following: Amber → red (5 blinks) → amber (5 blinks) → green (5 blinks) → <b>green/amber (5 blinks)</b> → red/amber (5 blinks) → solid green</li> </ul> </li> </ol>

<p><b><i>Set Gap Sensor as Media Sensor and Calibrate the Gap Sensor</i></b></p>	<ol style="list-style-type: none"> <li>1. Turn off the power switch.</li> <li>2. Hold on the button then turn on the power switch.</li> <li>3. Release the button when LED turns <b>red/amber</b> after 5 green/amber blinks. (Any red/amber will do during the 5 blinks). <ul style="list-style-type: none"> <li>■ The LED color will be changed as following: Amber → red (5 blinks) → amber (5 blinks) → green (5 blinks) → green/amber (5 blinks) → <b>red/amber (5 blinks)</b> → solid green</li> </ul> </li> </ol>
<p><b><i>Skip AUTO.BAS</i></b></p>	<ol style="list-style-type: none"> <li>1. Turn off printer power.</li> <li>2. Press the FEED button and then turn on power.</li> <li>3. Release the FEED button when LED becomes <b>solid green</b>. <ul style="list-style-type: none"> <li>■ The LED color will be changed as following: Amber → red (5 blinks) → amber (5 blinks) → green (5 blinks) → green/amber (5 blinks) → red/amber (5 blinks) → <b>solid green</b></li> </ul> </li> <li>4. Printer will be interrupted to run the AUTO.BAS program.</li> </ol>

## Revise History

Date	Content	Editor
2008/2/29	*Add 3.8 section: Diagnostic Tool *Add the IP Address default setting	Camille
2008/3/6	*Revise 2.2 section *Add 3.9 section: Install memory card	Camille
2008/3/7	*Revise the printer default setting *Revise 3.6, 4.2 and 5.1 section	Camille
2008/3/10	Revise the 6 section	Camille
2009/3/11	Revise 3.9 section (Recommended SD card specification)	Camille

